



Accordo

A tuneful speaker

ad Musicam ...

Ho sempre amato il piccolo diffusore, per la sua discrezione, per la minore criticità in ambiente, per la "magia" che spesso è in grado di creare nel riprodurre musica.
Con "**Accordo**" ho ripercorso schemi progettuali che mi sono particolarmente cari.
Un suono, una voce capace di toccare le profondità dell'anima...

A handwritten signature in black ink, appearing to read "Giancarlo Piretti". The signature is fluid and cursive, with a long horizontal stroke at the end.

*I have always loved small speakers, for their discreet presence, for their suitability in less critical environments, for the "magic" which they often are able to create in music reproduction.
With "**Accordo**", I followed design patterns that are particularly dear to me. A sound, a voice capable of reaching the depths of the soul...*

L'accordo è un fondamento della musica così come lo è l'accordatura per ogni strumento musicale. Che si tratti di una grande orchestra, del singolo strumento o di un brano musicale, alla base di tutto vi è sempre un accordo.

Dare la voce ad un diffusore significa accordarne le varie parti in un insieme armonico ed espressivo: dagli altoparlanti alle parti del crossover, dal cabinet fino al suo supporto, la singolarità di ciascun elemento si fonde in un unicum in grado di donare a chi ascolta la **qualità dell'illusione**.

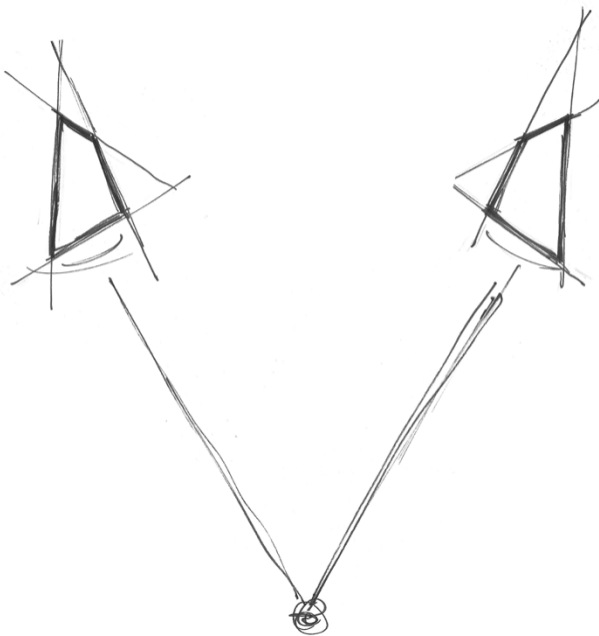

The chord is one of the foundations of music, essential for the tuning of a musical instrument. Without preconceptions, if we consider a large orchestra, a single instrument or a piece of music, there is a chord at the base of it all. Voicing a speaker involves the tuning and harmonising of the different parts into something uniquely expressive and coherent: from the drivers to the crossover parts, from the cabinet to its support, the singularity of each element blends into a whole, a presence capable of giving to listeners the "quality of illusion".



Il bello del limite: come superare con il piccolo la capacità evocativa del grande diffusore.
Miniaturizzare per espandere: togliere massa, ingombro e, naturalmente, estensione
per guadagnare aria e immediatezza. Una rinuncia che è una conquista.

*The beauty of limitations: how to surpass with a small speaker the evocative ability of a big one.
To miniaturise in order to expand: leaving mass, encumbrance and, of course, frequency
range to gain air and immediacy. A renunciation that is, in actuality, an achievement.*

Lo stand: elemento fondamentale per l'equilibrio estetico e funzionale, racchiude al suo interno il crossover, liberando la camera acustica della sua presenza; soluzione definitiva per evitare interferenze con gli altoparlanti.

The support: a fundamental element for aesthetic and functional balance, it also includes the crossover, freeing the acoustical chamber from its presence; a definitive solution to avoiding potential interference with the drivers.





Androne in Corso A. Palladio Vicenza, Italia

- **Geometry:** 2 way compact speaker - Specular design.
- **Cabinet:** Super-rigid, arch-shaped Solid wood structure decoupled with Aluminium - Magnesium parts to obtain resonance control. Handcrafted by artisan Masters.
- **Stand:** Especially designed to encase the crossover network. The ultimate solution to avoid transducer interference.
- **Tweeter:** 29 mm silk-dome by Ragnar Lian, one of the greatest masters among transducer designers. An on-going project for 30 years.
- **Mid-woofer:** Legendary, custom made, 150 mm sliced paper cone, optimized for the best control of cone break-up. Symmetrical drive motor system.
- **Crossover:** Minimalist approach, low-order, phase coherent, finalized to achieve precise soundstaging, focus and depth of image. Selected premium parts.

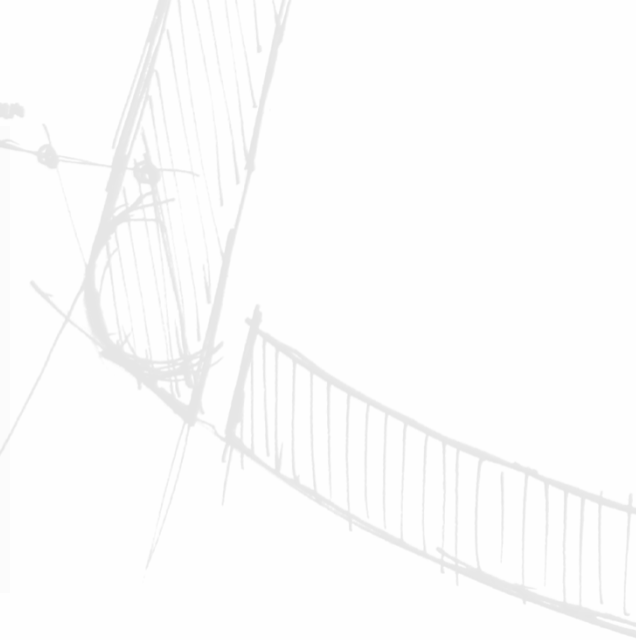
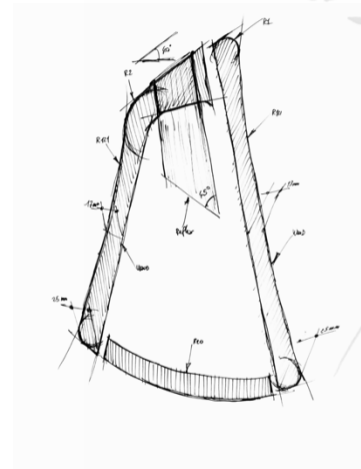

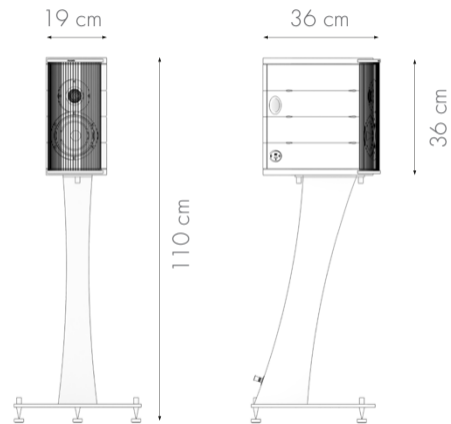

Frequency Response: 40 Hz - 33 KHz, in room

Nominal impedance: 4 ohm

Sensitivity: 87 dB /1W/1m

Minimum power amplifier: 20 W / ch minimum

Speaker dimensions: 36 cm x 19 cm x 36 cm (HWD)

Stand height: 74 cm

Weight: 32 Kg/pair - stand included (unpacked)

40 Kg/pair - stand included (unpacked)

Finish: Solid walnut - Metal parts chrome aluminium.

Grey Multilayered hardwood - Metal parts chrome aluminium.

Accordo

© Registered Design 2011
- Made in Italy -

www.francoserblin.it